

NO.	DESCRIPTIONS	MAT'L	SIZE	Q'TY	REMARKS
1	CASING	FRP	-	1 LOT	
2	SPRAY NOZZLE	PP	15A	1 LOT	
3	HOT WATER BASIN	FRP	-	2 EA	
4	INLET PIPE	SPP	200A	2 EA	10K FF
5	MOTOR COMM. BASE	SS400	#2400	1 SET	HDG
6	FAN STACK	FRP	#2400	1 SET	
7	FAN BLADE	AL-ALLOY	φ2400	1 SET	
8	BEARING HOUSING	FC	20HP	1 SET	6314 (70.95.13)
9	FAN PULLEY	FC	5V2203	1 EA	
10	V-BELT	RUBBER	5VX1060	1 SET	
11	MOTOR	TEFC	20HP 3φ 60Hz	1 SET	
12	MOTOR PULLEY	FC	5V503	1 EA	
13	LADDER	SPP	25A	1 LOT	HDG
14	FILL	PVC	-	1 LOT	
15	STRUCTURE	SS400	-	1 LOT	HDG
16	COLD WATER BASIN	FRP	-	1 SET	
17	OUTLET PIPE	SPP	250A	1 EA	10K FF
18	DRAIN BOX	SS400	2.3t	1 EA	HDG
19	FOUNDATION	RF CON'C	-	1 LOT	BY OWNER
-	SPRING MOUNT	FC	-	8 EA	

- 상기 수량은 1 CELL에 대한 것임.
- 본 기기와 연결되는 전선자재, 배관자재 및 공사는 공급범위에서 제외됨.
- 기초공사 제외

NO.	DATE	REVISIONS	REVIEWED	CHECKED	APPROVED

DESIGN CONDITIONS		NOZZLE SPECIFICATIONS						
WATER FLOW RATE	312 M <sup>3</sup> /HR	SYMBOL	DESCRIPTIONS	MAT'L	SIZE	Q'TY	REMARK	
NO. OF CELLS	1 CELL	a	MANUAL MAKE-UP	SPP	50 A	1 EA	FLANGE	
TEMP.	INLET	37 °C	b	AUTO. MAKE-UP	SPP	50 A	1 EA	FLANGE
	OUTLET	32 °C	c	OVERFLOW	SPP	80 A	1 EA	FLANGE
	WET BULB	27 °C	d	DRAIN	SPP	100 A	1 EA	FLANGE

NO.	DESCRIPTIONS	MAT'L	SIZE	Q'TY	REMARKS
		TITLE ASSEMBLY DRAWING LXP 400 RT		PROJECTION 	
DWG.	DSN.	CHK.	APPR.	SCALE	1 / 45
S.C.I.	S.S.H.	J.J.M.	R.H.H.	UNIT	mm
DATE		2007.		REF. NO.	
DWG. NO.		DI-LXP-400-01		REV. NO.	

NO.	DESCRIPTIONS	MAT'L	SIZE	Q'TY	REMARKS
-----	--------------	-------	------	------	---------

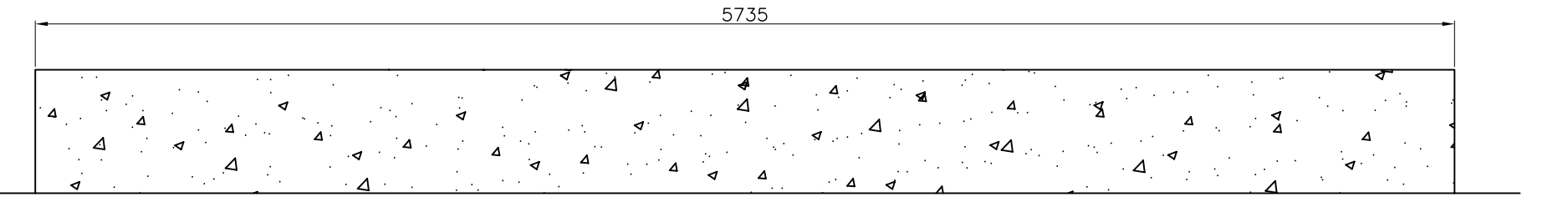
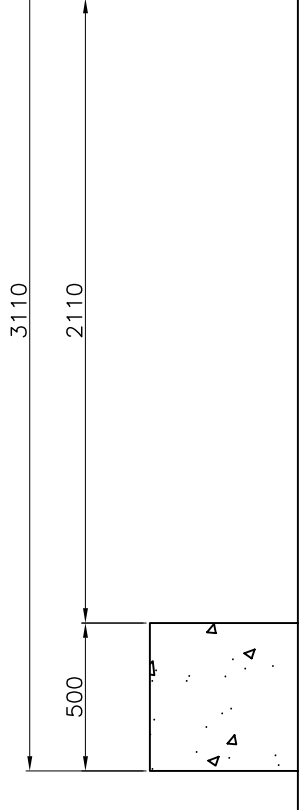
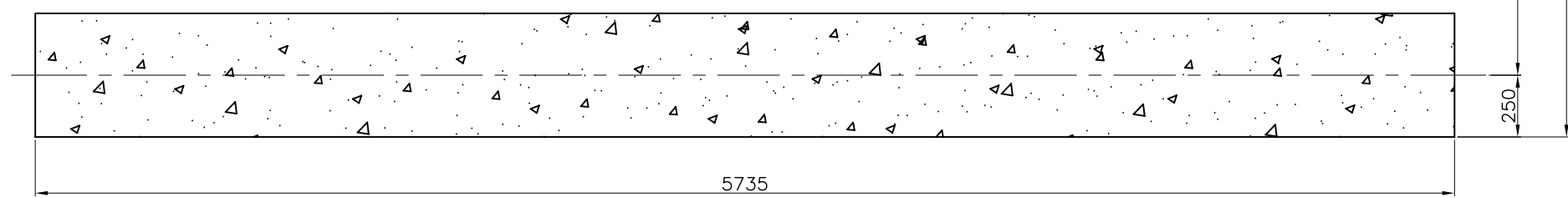
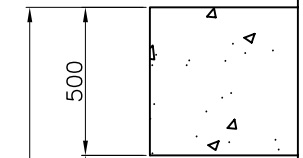
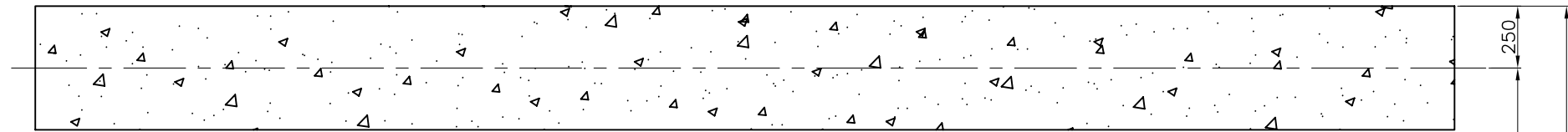

NO.	DATE	REVISIONS	REVIEWED	CHECKED	APPROVED
2					
1					

NO.	DESCRIPTIONS	MAT'L	SIZE	Q'TY	REMARKS
		TITLE FOUNDATION LXP-400-RT		PROJECTION 	
DWG.	DSN.	CHK.	APPR.	SCALE	1 / 25
S.C.I.	S.S.H.	J.J.M.	R.H.H.	UNIT	mm
				DATE	2005. 01.
				P.J.T NAME	
				REF. NO.	
				DWG. NO.	DI-LXP-400-02
				REV.NO.	

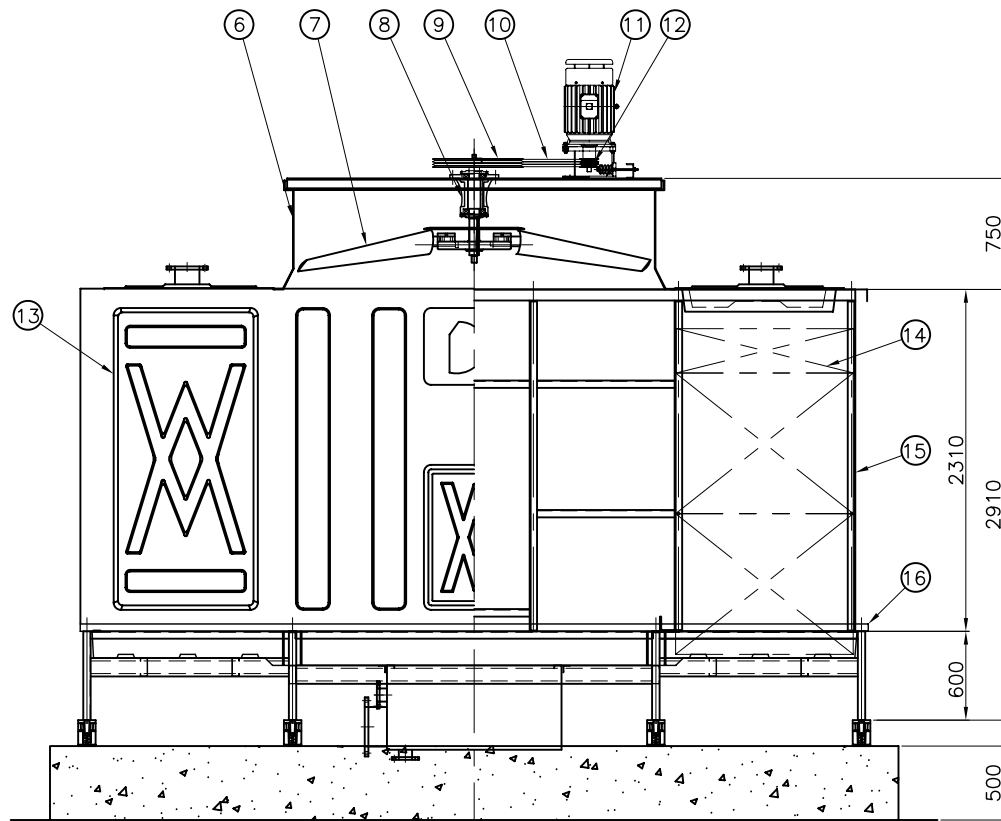
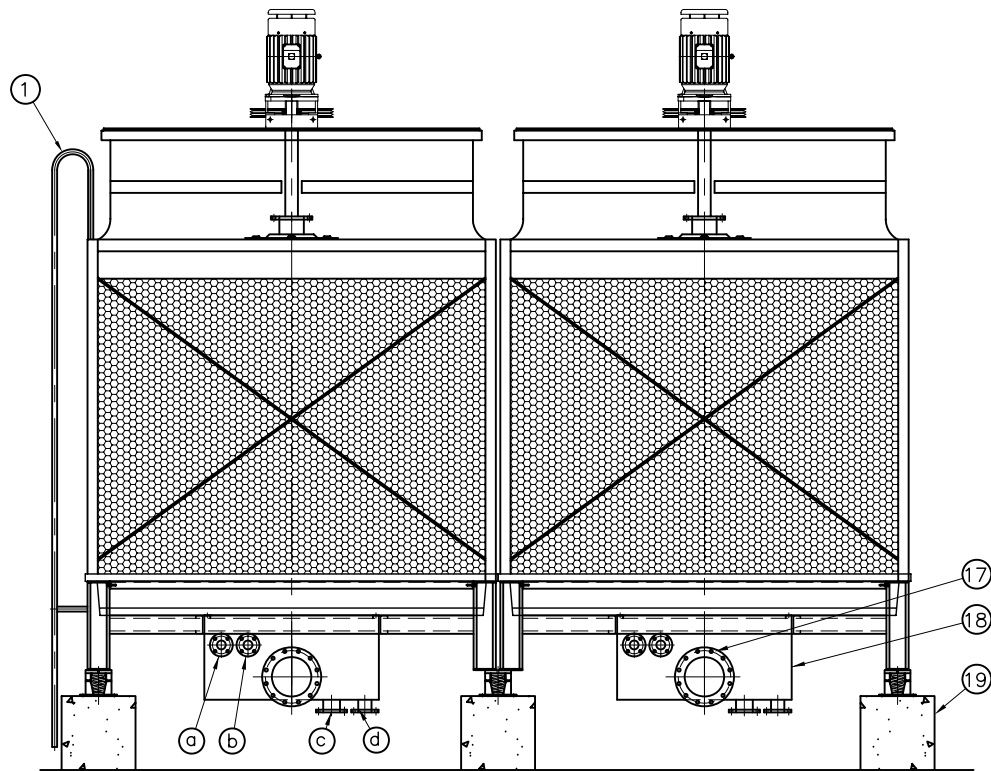
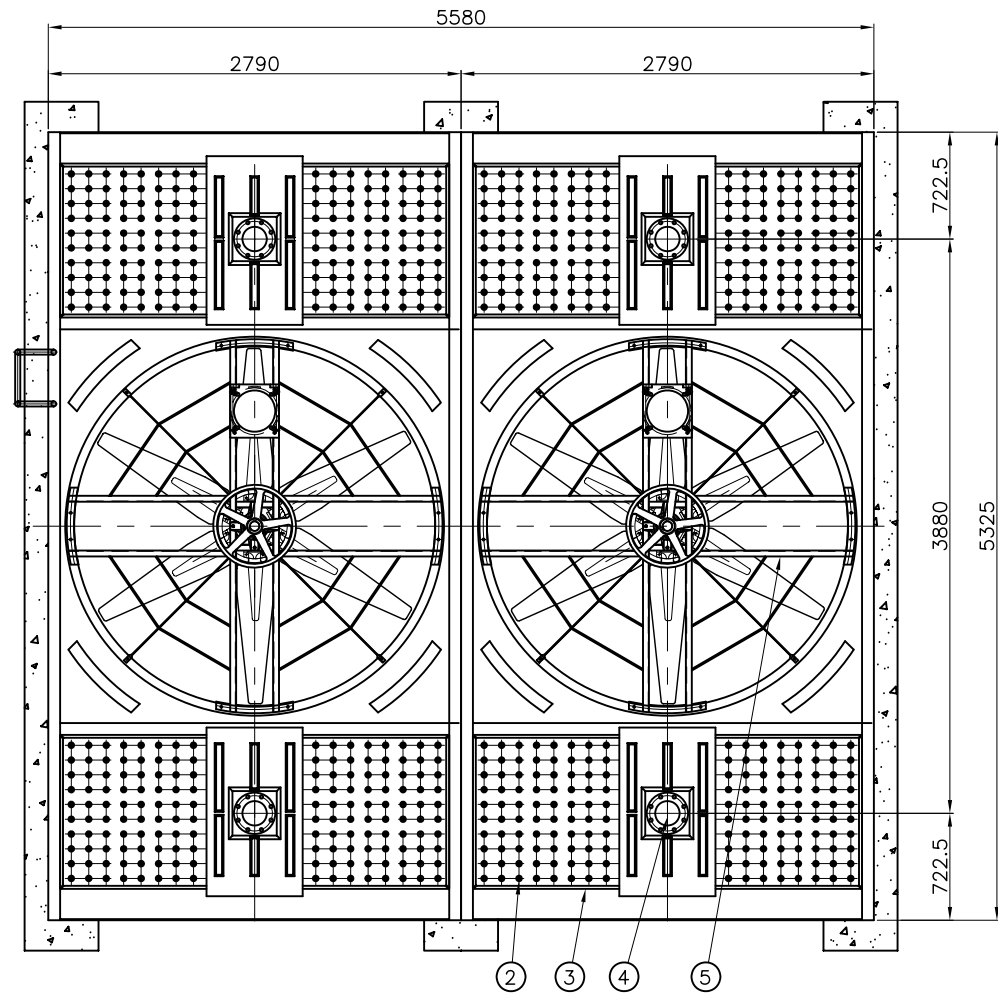

NO.	DESCRIPTIONS	MAT'L	SIZE	Q'TY	REMARKS
1	LADDER	SPP	25A	1 LOT	HDG
2	SPRAY NOZZLE	PP	15A	1 LOT	
3	HOT WATER BASIN	FRP	-	2 EA	
4	INLET PIPE	SPP	200A	2 EA	10K FF
5	MOTOR COMM. BASE	SS400	#2400	1 SET	HDG
6	FAN STACK	FRP	#2400	1 SET	
7	FAN BLADE	AL-ALLOY	φ2400	1 SET	
8	BEARING HOUSING	FC	20HP	1 SET	6314 (70.95.13)
9	FAN PULLEY	FC	5V2203	1 EA	
10	V-BELT	RUBBER	5VX1060	1 SET	
11	MOTOR	TEFC	20HP 3φ 60Hz	1 SET	
12	MOTOR PULLEY	FC	5V503	1 EA	
13	CASING	FRP	-	1 LOT	
14	FILL	PVC	-	1 LOT	
15	STRUCTURE	SS400	-	1 LOT	HDG
16	COLD WATER BASIN	FRP	-	1 SET	
17	OUTLET PIPE	SPP	250A	1 EA	10K FF
18	DRAIN BOX	SS400	2.3t	1 EA	HDG
19	FOUNDATION	RF CON'C	-	1 LOT	BY OWNER
-	SPRING MOUNT	FC	-	1 LOT	

- 상기 수량은 1 CELL에 대한 것임.
- 본 기기와 연결되는 전선자재, 배관자재 및 공사는 공급범위에서 제외됨.
- 기초공사 제외

DESIGN CONDITIONS			NOZZLE SPECIFICATIONS					
WATER FLOW RATE	624	M <sup>3</sup> /HR	SYMBOL	DESCRIPTIONS	MAT'L	SIZE	Q'TY	REMARK
NO. OF CELLS	2	CELL	a	MANUAL MAKE-UP	SPP	50 A	2 EA	FLANGE
TEMP.	INLET	37 °C	b	AUTO. MAKE-UP	SPP	50 A	2 EA	FLANGE
	OUTLET	32 °C	c	OVERFLOW	SPP	100 A	2 EA	FLANGE
	WET BULB	27 °C	d	DRAIN	SPP	80 A	2 EA	FLANGE

NO.	DESCRIPTIONS	MAT'L	SIZE	Q'TY	REMARKS
DWG. DSN. CHK. APPR. SCALE 1 / 50		P.J.T NAME		REV.NO.	
S.C.I. S.S.H. J.J.M. R.H.H. DATE 2007.		DWG. NO.		DI-LXP-400-2-01	

NO.	DATE	REVISIONS	REVIEWED	CHECKED	APPROVED

**DAEIL AQUA CO., LTD.**  
COOLING TOWER (주) 대 일 아 쿠 아

TITLE ASSEMBLY DRAWING  
LXP 400 RT. x 2 CELLS

PROJECTION

NO.	DESCRIPTIONS	MAT'L	SIZE	Q'TY	REMARKS
-----	--------------	-------	------	------	---------

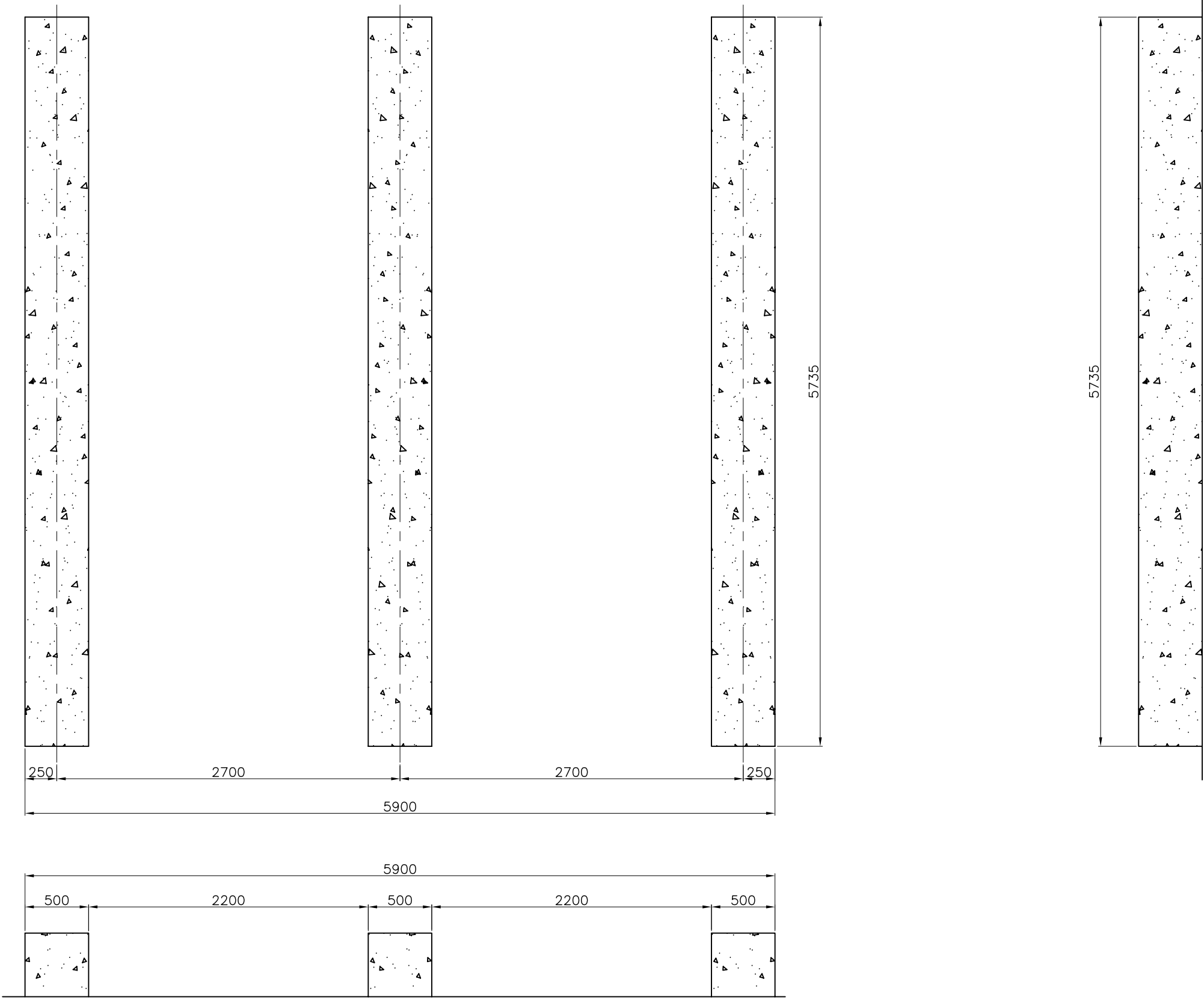

NO.	DATE	REVISIONS	REVIEWED	CHECKED	APPROVED

NO.	DESCRIPTIONS	MAT'L	SIZE	Q'TY	REMARKS
		TITLE FOUNDATION LXP 400 RT. x 2 CELLS		PROJECTION	
DWG.	DSN.	CHK.	APPR.	SCALE 1 / 35	P.J.T NAME
S.C.I.	S.S.H.	J.J.M.	R.H.H.	UNIT mm	REF. NO.
DATE 2005. 01.		DWG. NO. DI-LXP-400-2-02		REV. NO.	

NO.	DESCRIPTIONS	MAT'L	SIZE	Q'TY	REMARKS
1	LADDER	SPP	25A	1 LOT	HDG
2	SPRAY NOZZLE	PP	15A	1 LOT	
3	HOT WATER BASIN	FRP	-	2 EA	
4	INLET PIPE	SPP	200A	2 EA	10K FF
5	MOTOR COMM. BASE	SS400	#2400	1 SET	HDG
6	FAN STACK	FRP	#2400	1 SET	
7	FAN BLADE	AL-ALLOY	φ2400	1 SET	
8	BEARING HOUSING	FC	20HP	1 SET	6314 (70.95.13)
9	FAN PULLEY	FC	5V2203	1 EA	
10	V-BELT	RUBBER	5VX1060	1 SET	
11	MOTOR	TEFC	20HP 3φ 60Hz	1 SET	
12	MOTOR PULLEY	FC	5V503	1 EA	
13	CASING	FRP	-	1 LOT	
14	FILL	PVC	-	1 LOT	
15	STRUCTURE	SS400	-	1 LOT	HDG
16	COLD WATER BASIN	FRP	-	1 SET	
17	OUTLET PIPE	SPP	250A	1 EA	10K FF
18	DRAIN BOX	SS400	2.3t	1 EA	HDG
19	FOUNDATION	RF CON'C	-	1 LOT	BY OWNER
-	SPRING MOUNT	FC	-	1 LOT	

- 상기 수량은 1 CELL에 대한 것임.
- 본 기기와 연결되는 전선자재, 배관자재 및 공사는 공급범위에서 제외됨.
- 기초공사 제외

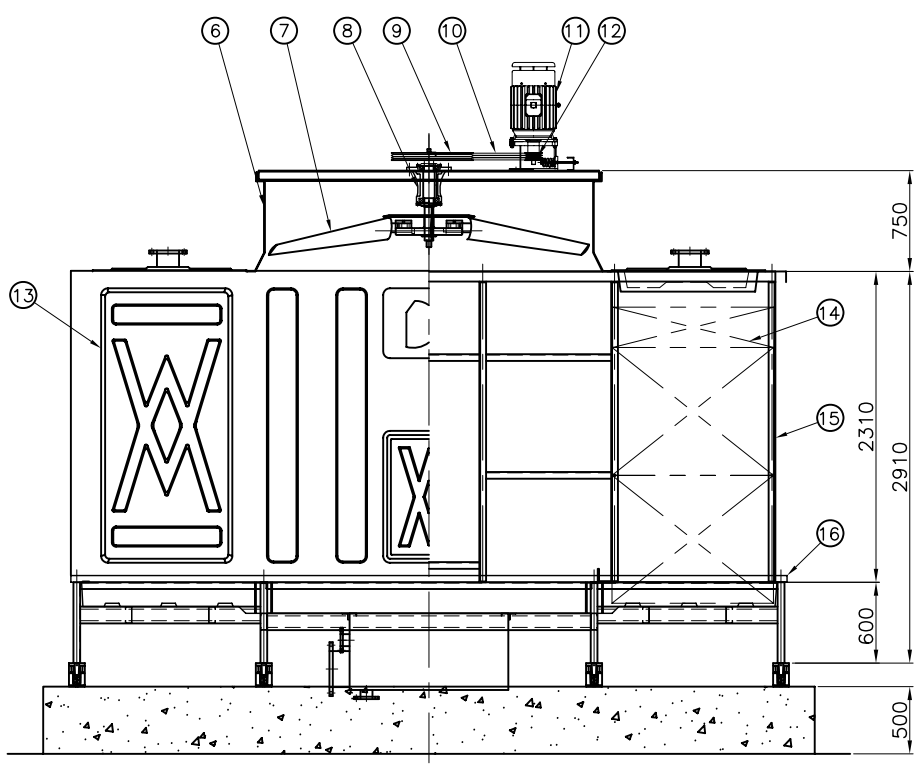
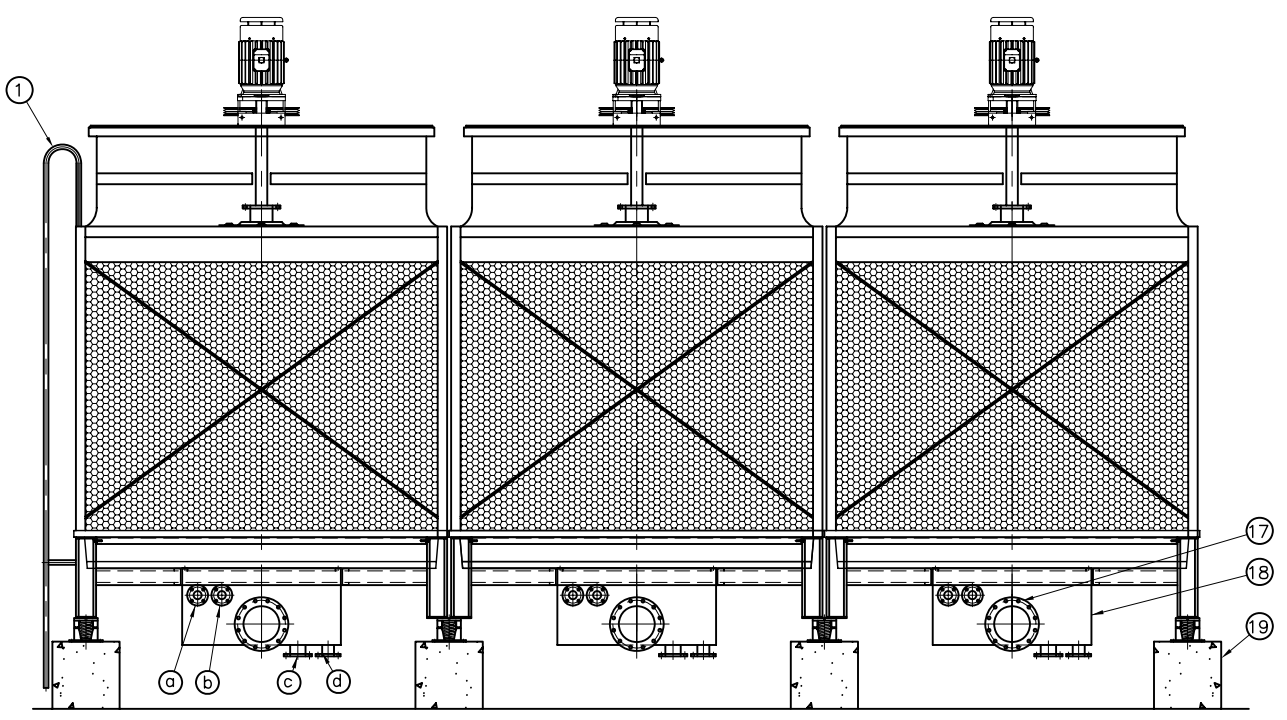
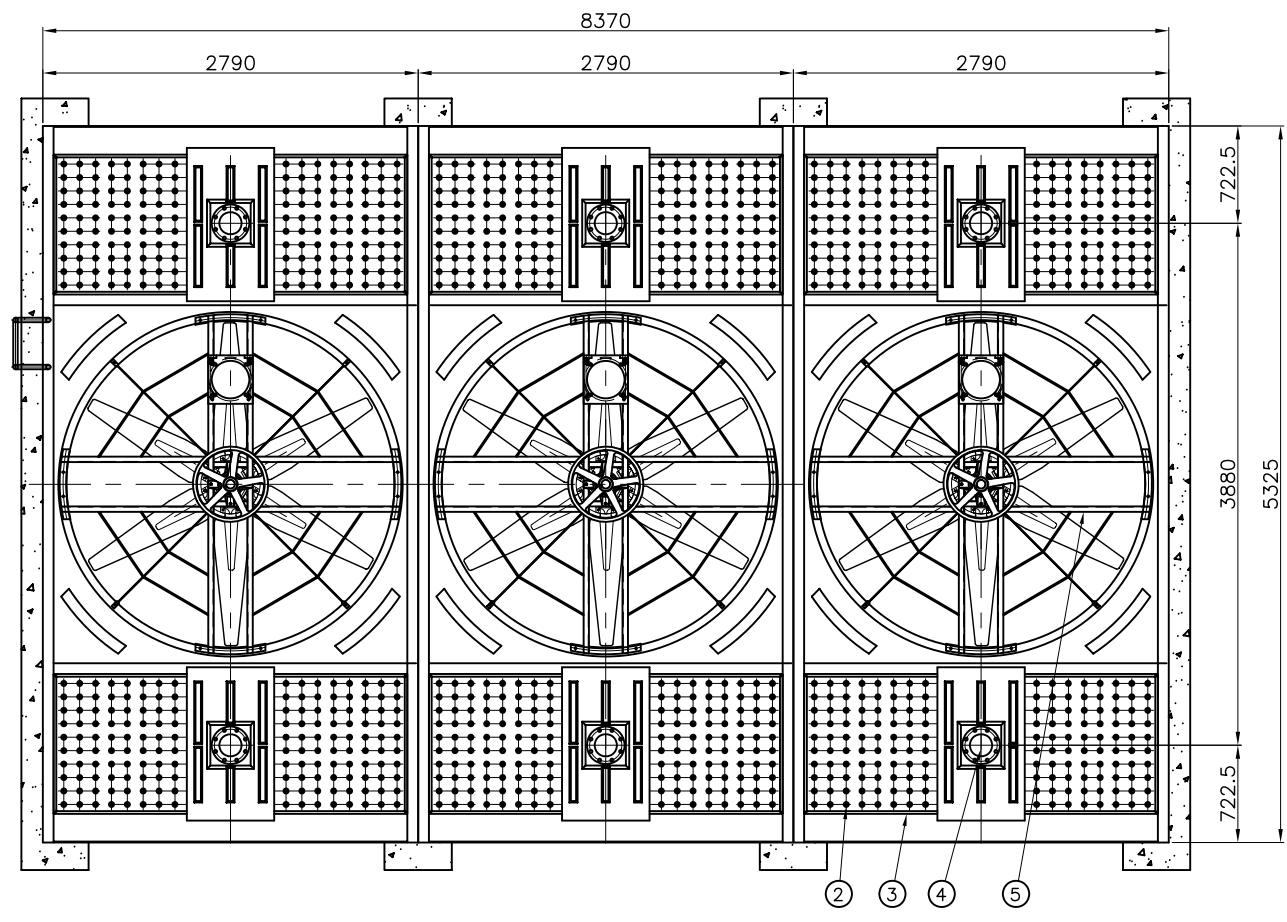

DESIGN CONDITIONS		NOZZLE SPECIFICATIONS						
WATER FLOW RATE	936 M <sup>3</sup> /HR	SYMBOL	DESCRIPTIONS	MAT'L	SIZE	Q'TY	REMARK	
NO. OF CELLS	3 CELL	a	MANUAL MAKE-UP	SPP	50 A	3 EA	FLANGE	
TEMP.	INLET	37 °C	b	AUTO. MAKE-UP	SPP	50 A	3 EA	FLANGE
	OUTLET	32 °C	c	OVERFLOW	SPP	100 A	3 EA	FLANGE
	WET BULB	27 °C	d	DRAIN	SPP	80 A	3 EA	FLANGE

NO.	DESCRIPTIONS	MAT'L	SIZE	Q'TY	REMARKS
<b>DAEIL AQUA CO., LTD.</b> COOLING TOWER (주) 대 일 아 쿠 아					TITLE ASSEMBLY DRAWING LXP 400 RT. x 3 CELLS
DWG.	DSN.	CHK.	APPR.	SCALE	1 / 55
S.C.I.	S.S.H.	J.J.M.	R.H.H.	UNIT	mm
				DATE	2007.
				P.J.T NAME	
				REF. NO.	
				DWG. NO.	DI-LXP-400-3-01

NO.	DATE	REVISIONS	REVIEWED	CHECKED	APPROVED

NO.	DESCRIPTIONS	MAT'L	SIZE	Q'TY	REMARKS
-----	--------------	-------	------	------	---------

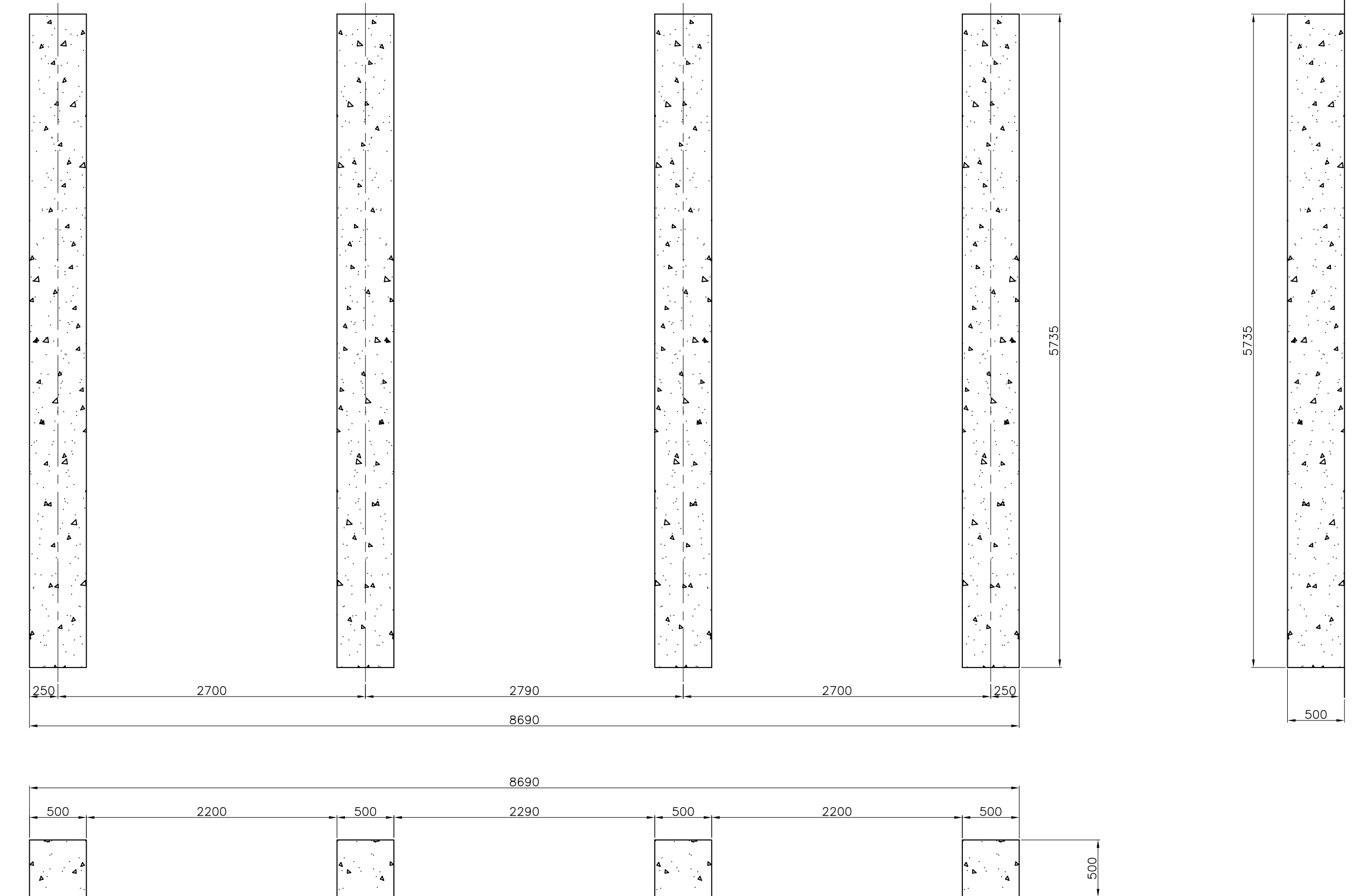

NO.	DATE	REVISIONS	REVIEWED	CHECKED	APPROVED

NO.	DESCRIPTIONS	MAT'L	SIZE	Q'TY	REMARKS
		TITLE FOUNDATION LXP 400 RT. x 3 CELLS		PROJECTION 	
DWG.	DSN.	CHK.	APPR.	SCALE	1 / 35
S.C.I.	S.S.H.	J.J.M.	R.H.H.	UNIT	mm
DATE		2005. 01.		REF. NO.	DWG. NO.
					DI-LXP-400-3-02
					REV.NO.

NO.	DESCRIPTIONS	MAT'L	SIZE	Q'TY	REMARKS
1	LADDER	SPP	25A	1 LOT	HDG
2	SPRAY NOZZLE	PP	15A	1 LOT	
3	HOT WATER BASIN	FRP	-	2 EA	
4	INLET PIPE	SPP	200A	2 EA	10K FF
5	MOTOR COMM. BASE	SS400	#2400	1 SET	HDG
6	FAN STACK	FRP	#2400	1 SET	
7	FAN BLADE	AL-ALLOY	φ2400	1 SET	
8	BEARING HOUSING	FC	20HP	1 SET	6314 (70.95.13)
9	FAN PULLEY	FC	5V2203	1 EA	
10	V-BELT	RUBBER	5VX1060	1 SET	
11	MOTOR	TEFC	20HP 3φ 60Hz	1 SET	
12	MOTOR PULLEY	FC	5V503	1 EA	
13	CASING	FRP	-	1 LOT	
14	FILL	PVC	-	1 LOT	
15	STRUCTURE	SS400	-	1 LOT	HDG
16	COLD WATER BASIN	FRP	-	1 SET	
17	OUTLET PIPE	SPP	250A	1 EA	10K FF
18	DRAIN BOX	SS400	2.3t	1 EA	HDG
19	FOUNDATION	RF CON'C	-	1 LOT	BY OWNER
-	SPRING MOUNT	FC	-	1 LOT	

- 상기 수량은 1 CELL에 대한 것임.
- 본 기기와 연결되는 전선자재, 배관자재 및 공사는 공급범위에서 제외됨.
- 기초공사 제외

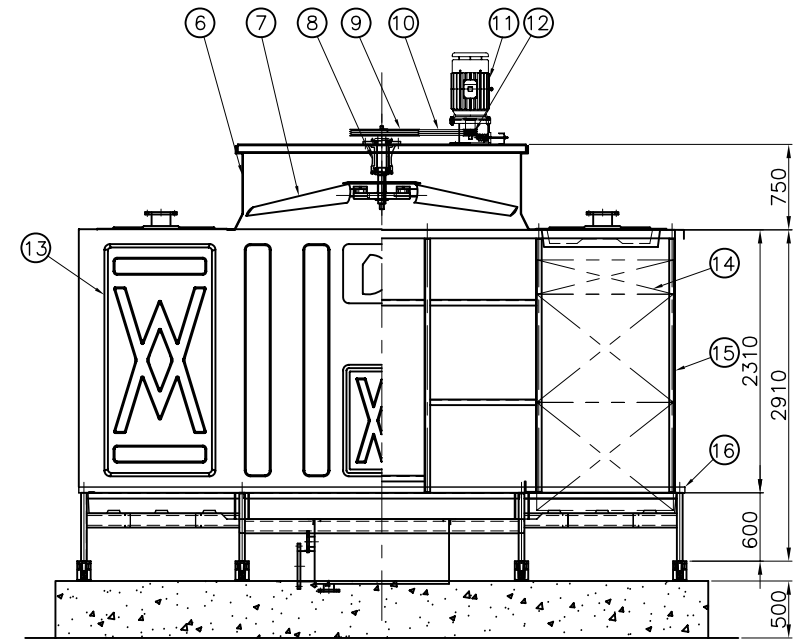
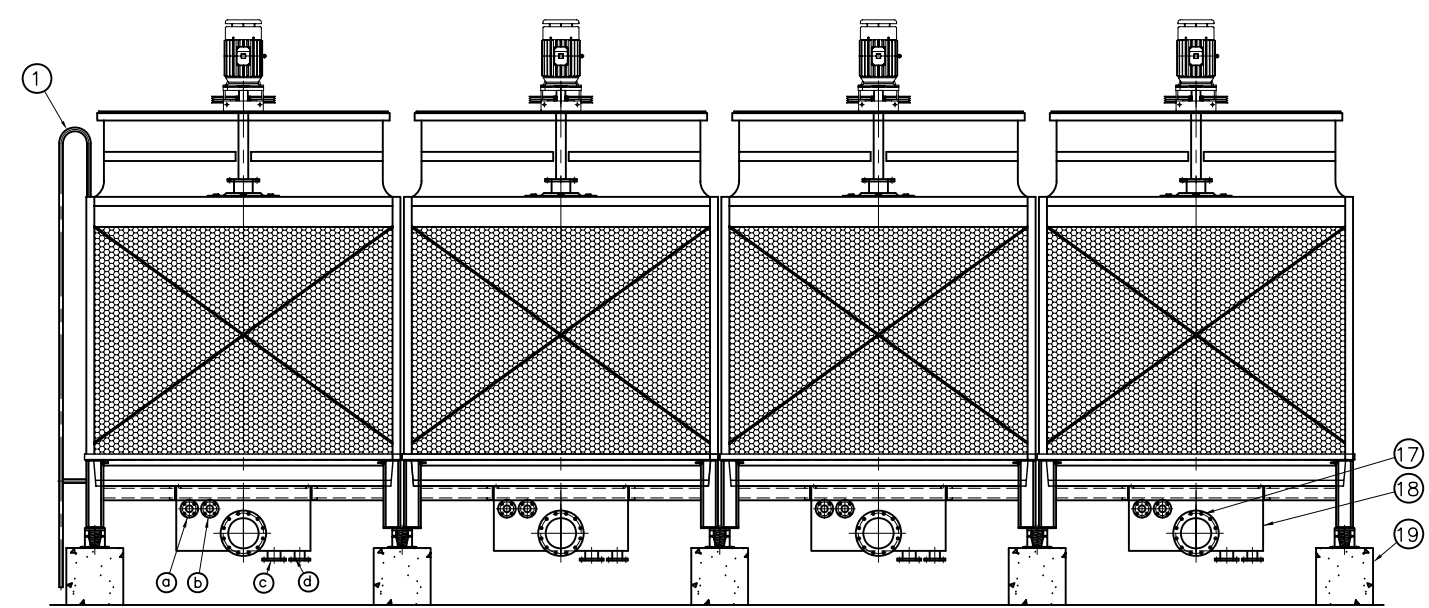
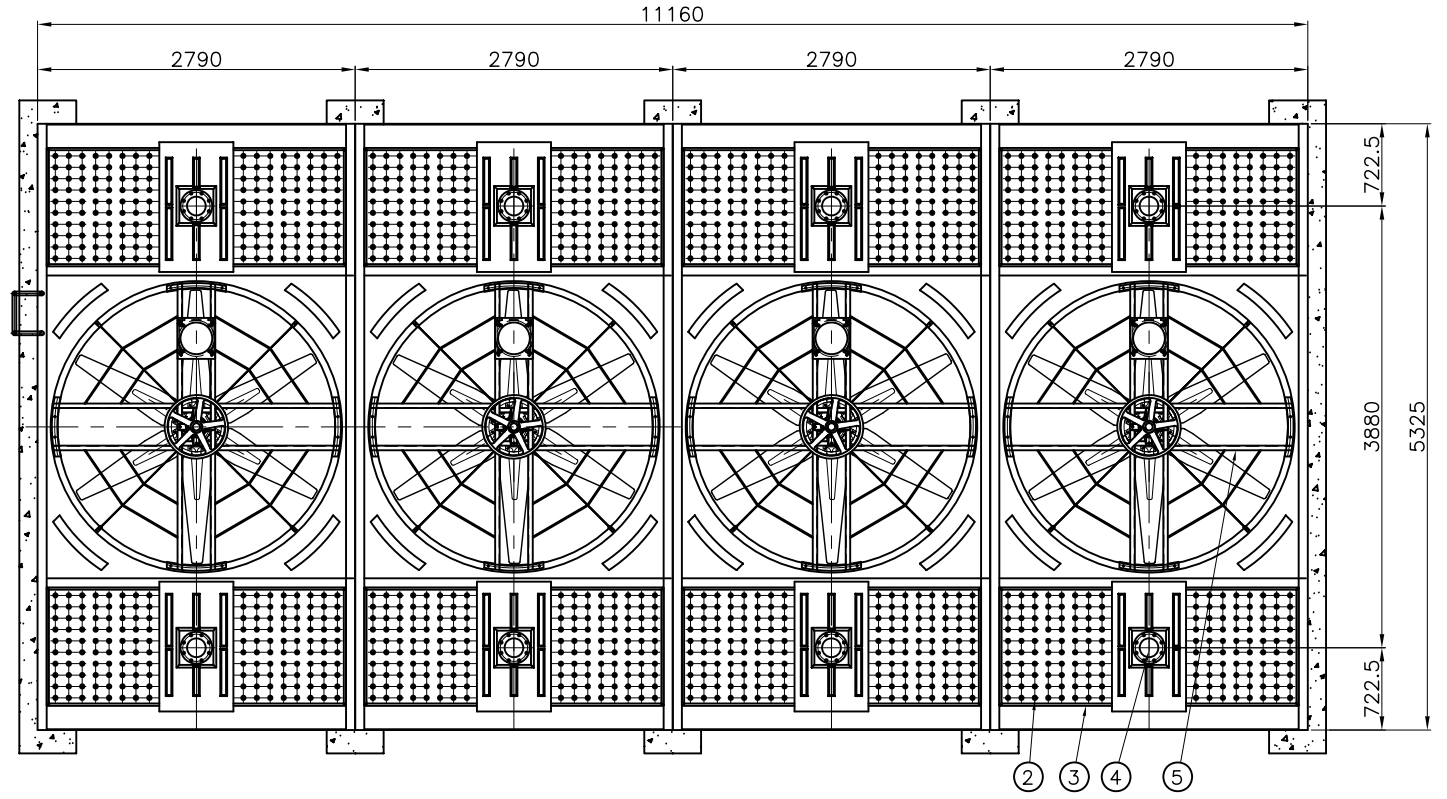

NO.	DATE	REVISIONS	REVIEWED	CHECKED	APPROVED

DESIGN CONDITIONS		NOZZLE SPECIFICATIONS						
WATER FLOW RATE	1248 M <sup>3</sup> /HR	SYMBOL	DESCRIPTIONS	MAT'L	SIZE	Q'TY	REMARK	
NO. OF CELLS	4 CELL	a	MANUAL MAKE-UP	SPP	50 A	4 EA	FLANGE	
TEMP.	INLET	37 °C	b	AUTO. MAKE-UP	SPP	50 A	4 EA	FLANGE
	OUTLET	32 °C	c	OVERFLOW	SPP	100 A	4 EA	FLANGE
	WET BULB	27 °C	d	DRAIN	SPP	80 A	4 EA	FLANGE

NO.	DESCRIPTIONS	MAT'L	SIZE	Q'TY	REMARKS
<b>DAEIL AQUA CO., LTD.</b> COOLING TOWER (주) 대 일 아 쿠 아					TITLE ASSEMBLY DRAWING LXP 400 RT. x 4 CELLS
DWG.	DSN.	CHK.	APPR.	SCALE	1 / 65
S.C.I.	S.S.H.	J.J.M.	R.H.H.	UNIT	mm
				DATE	2007.
				P.J.T NAME	REF. NO.
				DWG. NO.	DI-LXP-400-4-01

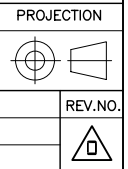

NO.	DESCRIPTIONS	MAT'L	SIZE	Q'TY	REMARKS
-----	--------------	-------	------	------	---------

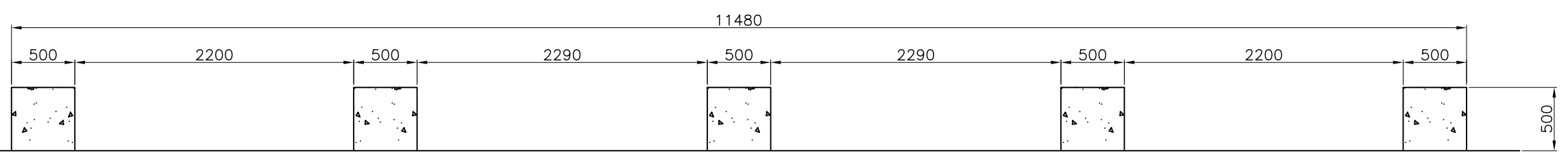
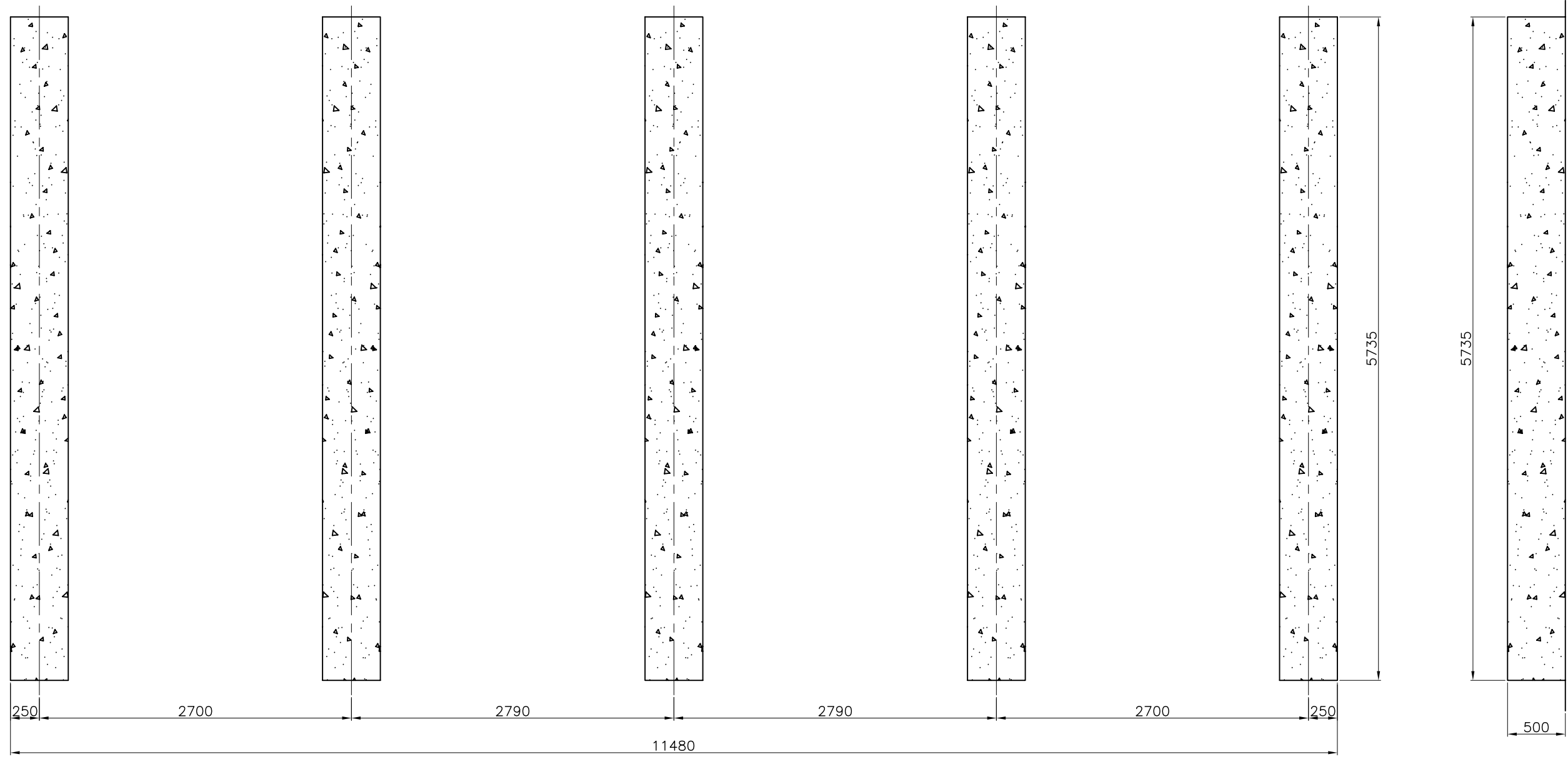

NO.	DATE	REVISIONS	REVIEWED	CHECKED	APPROVED

NO.	DESCRIPTIONS	MAT'L	SIZE	Q'TY	REMARKS
		TITLE FOUNDATION LXP 400 RT x 4 CELLS		PROJECTION 	
DWG.	DSN.	CHK.	APPR.	SCALE	1 / 40
S.C.I.	S.S.H.	J.J.M.	R.H.H.	UNIT	mm
DATE		2005. 01.		REF. NO.	DWG. NO.
				DI-LXP-400-4-02	
					REV.NO.



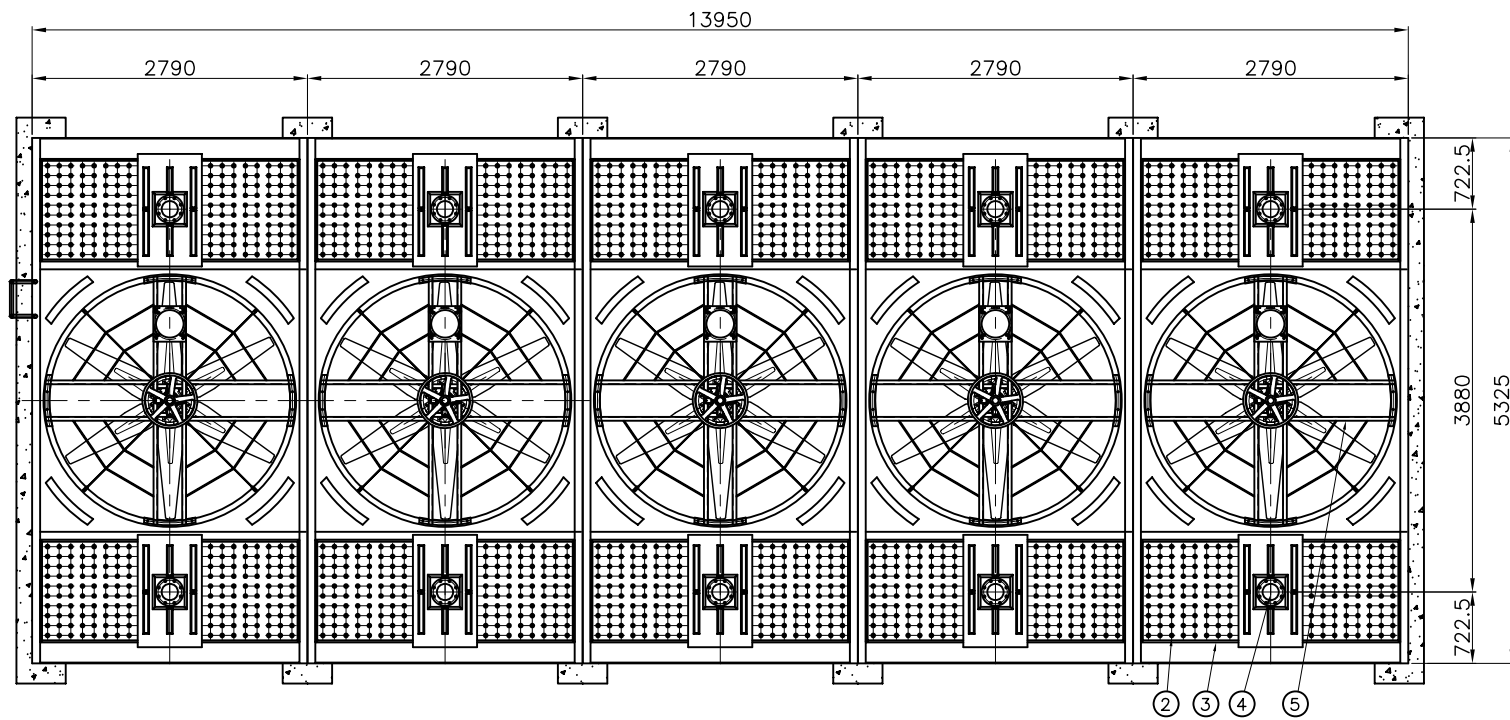

NO.	DESCRIPTIONS	MAT'L	SIZE	Q'TY	REMARKS
1	LADDER	SPP	25A	1 LOT	HDG
2	SPRAY NOZZLE	PP	15A	1 LOT	
3	HOT WATER BASIN	FRP	-	2 EA	
4	INLET PIPE	SPP	200A	2 EA	10K FF
5	MOTOR COMM. BASE	SS400	#2400	1 SET	HDG
6	FAN STACK	FRP	#2400	1 SET	
7	FAN BLADE	AL-ALLOY	φ2400	1 SET	
8	BEARING HOUSING	FC	20HP	1 SET	6314 (70.95.13)
9	FAN PULLEY	FC	5V2203	1 EA	
10	V-BELT	RUBBER	5VX1060	1 SET	
11	MOTOR	TEFC	20HP 3φ 60Hz	1 SET	
12	MOTOR PULLEY	FC	5V503	1 EA	
13	CASING	FRP	-	1 LOT	
14	FILL	PVC	-	1 LOT	
15	STRUCTURE	SS400	-	1 LOT	HDG
16	COLD WATER BASIN	FRP	-	1 SET	
17	OUTLET PIPE	SPP	250A	1 EA	10K FF
18	DRAIN BOX	SS400	2.3t	1 EA	HDG
19	FOUNDATION	RF CON'C	-	1 LOT	BY OWNER
-	SPRING MOUNT	FC	-	1 LOT	

- 상기 수량은 1 CELL에 대한 것임.
- 본 기기와 연결되는 전선자재, 배관자재 및 공사는 공급범위에서 제외됨.
- 기초공사 제외

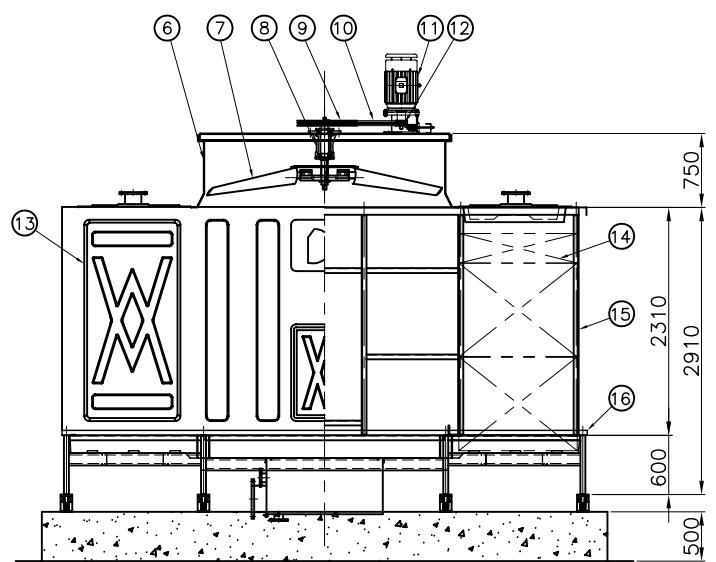
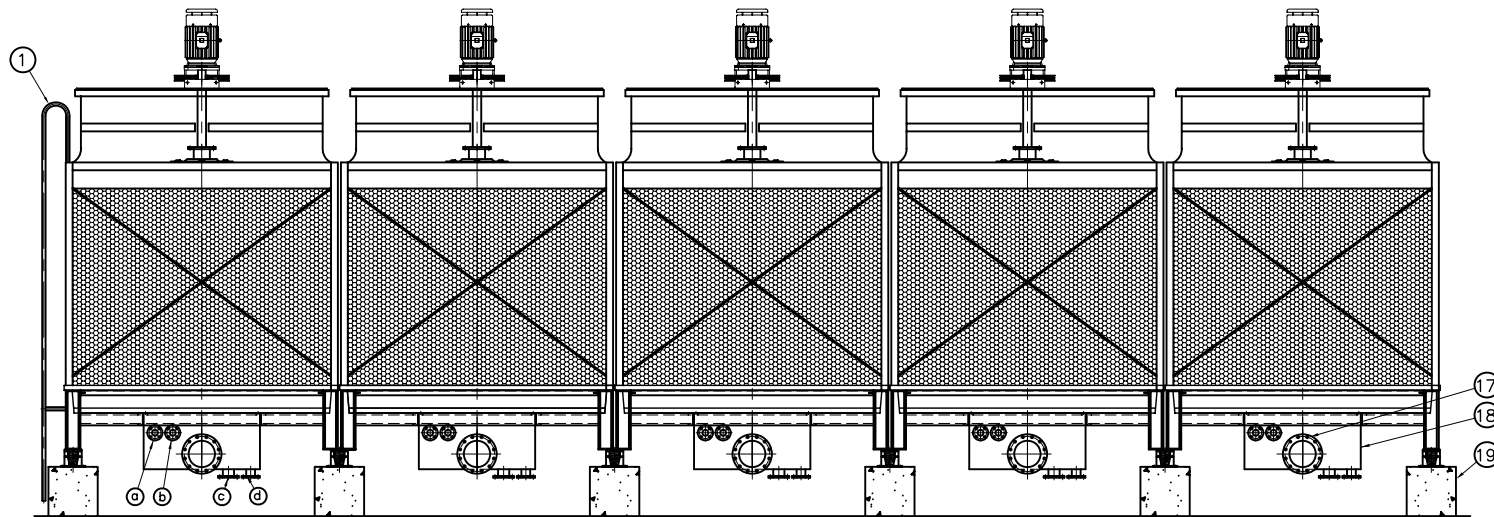

NO.	DATE	REVISIONS	REVIEWED	CHECKED	APPROVED

DESIGN CONDITIONS		NOZZLE SPECIFICATIONS						
WATER FLOW RATE	1560 M <sup>3</sup> /HR	SYMBOL	DESCRIPTIONS	MAT'L	SIZE	Q'TY	REMARK	
NO. OF CELLS	5 CELL	a	MANUAL MAKE-UP	SPP	50 A	5 EA	FLANGE	
TEMP.	INLET	37 °C	b	AUTO. MAKE-UP	SPP	50 A	5 EA	FLANGE
	OUTLET	32 °C	c	OVERFLOW	SPP	100 A	5 EA	FLANGE
	WET BULB	27 °C	d	DRAIN	SPP	80 A	5 EA	FLANGE

NO.	DESCRIPTIONS	MAT'L	SIZE	Q'TY	REMARKS
DWG. DSN. CHK. APPR. SCALE 1 / 75		P.J.T NAME		REV.NO.	
S.C.I. S.S.H. J.J.M. R.H.H. DATE 2007.		REF. NO.		DWG. NO. DI-LXP-400-5-01	

**DAEIL AQUA CO., LTD.**  
COOLING TOWER (주) 대 일 아 쿠 아

TITLE ASSEMBLY DRAWING  
LXP 400 RT. x 5 CELLS

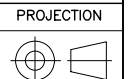

NO.	DESCRIPTIONS	MAT'L	SIZE	Q'TY	REMARKS
-----	--------------	-------	------	------	---------

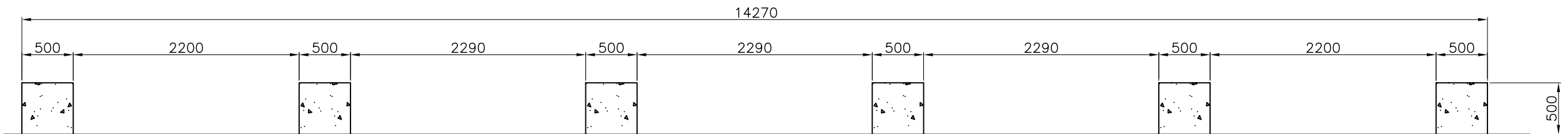
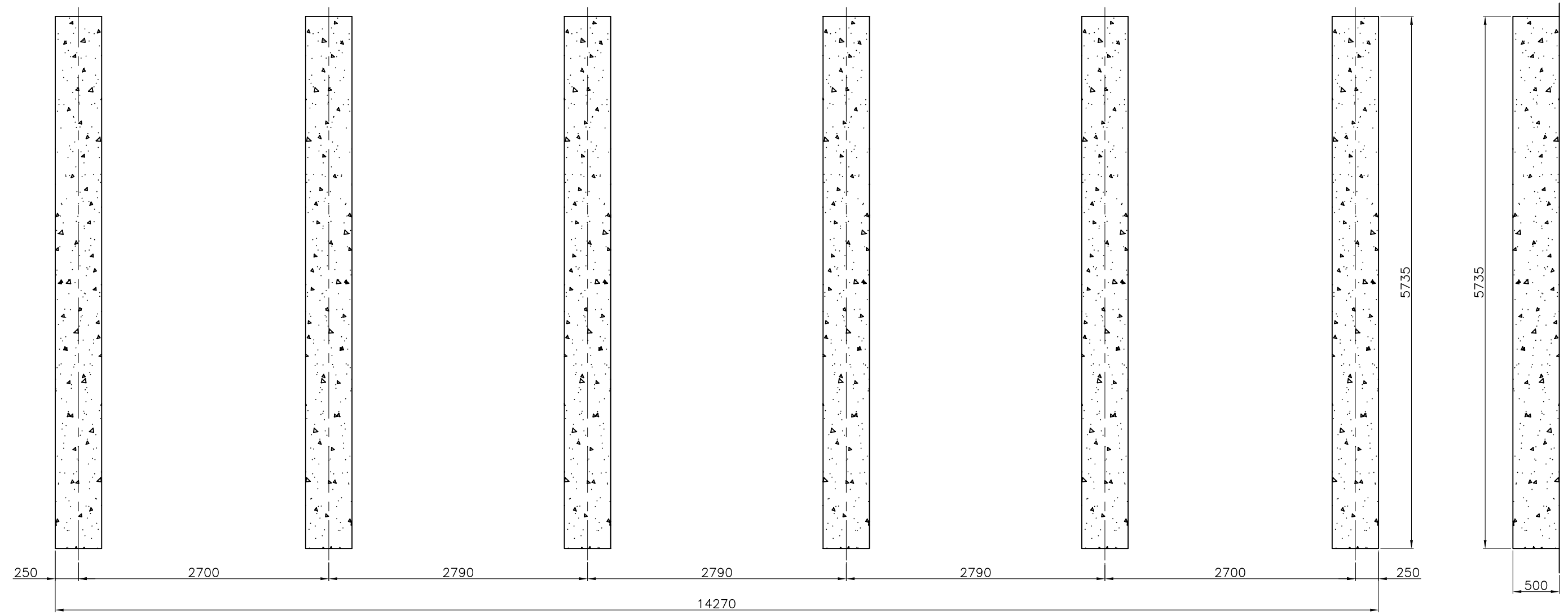

NO.	DATE	REVISIONS	REVIEWED	CHECKED	APPROVED

NO.	DESCRIPTIONS	MAT'L	SIZE	Q'TY	REMARKS
		TITLE FOUNDATION LXP 400 RT x 5 CELLS		PROJECTION 	
DWG.	DSN.	CHK.	APPR.	SCALE	1 / 45
S.C.I.	S.S.H.	J.J.M.	R.H.H.	UNIT	mm
DATE		2005. 01.		REF. NO.	DWG. NO.
				DI-LXP-400-5-02	
					REV.NO.